

# Omega<sup>®</sup> System 700

C-700 Condenser Enlarger  
and  
Super Chromega C-700 Dichroic Enlarger

## Instruction Manual



# Important Safeguards

When using your Omega Photographic products, basic safety precautions should always be taken, including the following:

1. Read and understand all instructions provided with this product.
2. Close supervision is necessary when this product is used by or near children. Do not leave it unattended while it is plugged into an outlet.
3. Avoid touching the lamp area of lamphouse or other hot parts as it may cause burns.
4. Do not operate this product if the power supply cord has been damaged or if the product has been dropped or damaged. Have lamphouse checked out and repaired if necessary by qualified service men before using.
5. Route the power supply cord away from hot areas. Do not let the cord hang over a counter edge or across an open area where people pass.
6. If an extension cord is necessary, use one with a suitable rating. Cords rated for less amperage than the product may overheat. Route the extension cord away from open areas where it may be tripped over or pulled.
7. Always unplug the product after use. Grasp the plug and firmly pull from the outlet to disconnect. Never yank the cord from the outlet.
8. Allow the product to cool to room temperature before storing. Wrap the power cord loosely around the product.
9. Do not immerse this product in water or other liquids.
10. To avoid electric shocks, do not attempt to disassemble or repair this product. Always have it serviced by qualified servicemen when necessary. Incorrect reassembly can cause electric shock hazards.

These safeguards are prescribed by Underwriters Laboratories to be included in this instruction sheet for U.L. listed products. Some precautions may not apply to this product.

## Save These Instructions

# Maintenance

Basically, only two routine operations are required:

1. **Cleaning:**
  - a. Remove any foreign material from enlarging lenses and condensers with lens tissue.
  - b. Clean the lamp with a soft lint-free cloth. (Does not apply to Chromega B Dichroic). Do not attempt to clean or adjust the dichroic filters as this may result in permanent damage.
2. **Lubrication and Tension Adjustment:**

Apply a thin film of grease or silicon lubricant on the focus rails and counterbalance spring. After removing any excess lubricant, adjust the tension of the focusing knob to your preference. This is done by tightening or loosening the small Phillips head screws at the front of the focus drive assembly. This should be done once or twice each year, or sooner if stiffness of operation is noticed. Check and tighten the lifting lever assembly and baseboard.

# General Information

Thank you for selecting an Omega System 700 enlarger. We are confident it will serve you well. This enlarger, like all our products, has been carefully designed and manufactured with only the finest materials.

Please read this instruction manual before attempting to assemble and operate your enlarger. This will help avoid errors and possible damage.

This manual covers both the Omega C-700 Condenser Enlarger and the Super Chromega C-700 Dichroic Color Enlarger. Except for the lamphouse, these models are identical and most of the information is common to both. Where instructions apply to only one model, it is so indicated.

Also, please keep in mind that as an Omega owner you are invited to call or write for darkroom advice or assistance. Please direct such inquiries to the attention of our Customer Service Department. Thank you!

Omega  
Woodside, New York 11377

# Table of Contents

	Page
Important Safeguards	2
Maintenance	2
General Information	2
Parts Identification	4
Unpacking	5
Chassis Assembly	6
Condenser Lamphouse Assembly	7
Dichroic Lamphouse Assembly	8
Electrical Connections	9
Operating Your System 700	9
Enlarging Lenses	11
Black and White Printing Hints	11
Color Printing Hints	12
Lamp Replacement	13
Specifications	13
Recommended Reading	14
Accessories	15

## OMEGA C-700 CONDENSER ENLARGER

The Omega C-700 enlarger accepts all negative formats up to 2 1/4" x 2 3/4" (6x7cm). While primarily intended for black and white work, its built-in filter drawer permits you to make color prints with the aid of standard 3" (75mm) square acetate color printing (CP) filters. The filter drawer also accepts variable contrast filters for use with Black and White variable contrast papers such as Kodak's Poly-contrast, and Polycontrast Rapid.

The C-700 is extremely rugged, smooth-operating and easy to use. Its features include a parallel action high-lift lamphouse for convenient carrier insertion and negative dusting. The enlarger has a very bright and even illumination system based on the use of a specially designed 75W lamp and clear-glass, striation-free condensers. This assures short exposure times and high quality, sparkling prints. A broad accessory program, including a dichroic color lamphouse, lets you match your enlarger system to your present and future needs.

## SUPER CHROMEGA C-700 DICHOIC ENLARGER

The color version of the "700" System uses the Super Chromega C-700 Dichroic lamphouse. This lamphouse is adaptable to any Omega B-66, B-600, Concept Six, B-22, C-700, or C67-XL (with accessory adapter) enlarger chassis. It offers a filtration range of 0-200cc's through the use of special dichroic glass filters which produce very pure color in the "subtractive" primary colors of cyan, magenta, and yellow. These filters are permanent, and will not fade in normal use.

Illumination is provided by a specially designed prefocused 85 Watt, 82 Volt quartz-halogen lamp with integral reflector. The built-in solid state power supply eliminates the need for an external power supply. An optional solid state Voltage Stabilizer, Catalog Number 403-730 is available.

Quartz-halogen lamps typically produce extremely consistent light output and color temperature, and are

designed to have an operating life of approximately 50 hours.

To ensure maximum light output and evenness of illumination, a system of interchangeable mixing chambers and diffusers was developed. Your Super Chromega C-700 Dichroic lamphouse comes with interchangeable mixing chambers and tapered diffusers for formats to 35mm, and for formats to 2 1/4" x 2 3/4" (6x7cm).

The filtration adjustment controls are color coded and the three reference scales are illuminated and magnified, with indicated increments of 1cc. A positive zero position detent secures the unused filters to prevent unwanted "neutral density". Both infrared and ultra-violet filtration are built-in.

As an aid in focusing, a white light lever allows you to increase illumination by removing the dichroic filters from the light path without disturbing the settings.

Another unique feature of the Super Chromega C-700 Dichroic Lamphouse is the ability to control light output to obtain optimum *f*/stop and exposure time. This is done with the use of three light attenuators which will reduce light output by -1 EV, -2 EV, -3 EV respectively.

In addition to its suitability for color printing from negatives and transparencies, the full light diffusion provided by the lamphouse design is often preferred for black and white printing. Dust, scratches, and imperfections in the negative are "suppressed" by the diffused light, yet full image sharpness is obtained. Equivalent contrast to that provided by a condenser light source is obtained by using approximately one paper grade "harder" material. The filters built into the lamphouse can also be used for variable contrast equivalencies.

With a simple adapter (Copy Camera Attachment, Cat. No. 429-062) the carriage of your enlarger can be converted to use most single lens reflex cameras for copy work. And by inverting the Super Chromega C-700 dichroic lamphouse on the baseboard, you have an ideal slide duplication system with full color control.

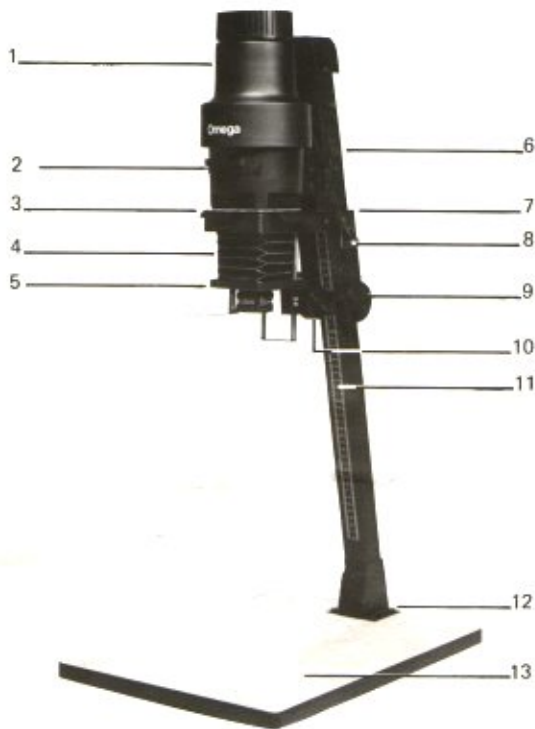

Figure 1: C-700 Condenser Enlarger



Figure 2: C-700 Condenser Enlarger



Figure 3: Super Chromega C-700 Dichroic Lamphouse

1. Upper Lamphouse
2. Condenser Housing
3. Negative Stage
4. Bellows
5. Lens Stage
6. Girder
7. Carriage Assembly
8. Cord Clamp
9. Combination Carriage Lock and Lifting Knob
10. Focusing Knob
11. Magnification Reference Scale
12. Chassis Mounting Bolts (4)
13. Baseboard
14. Counterbalance Spring
15. Alignment Screws
16. Lamphouse Lifting Lever
17. Lifting Lever Stop
18. Dual Focusing Rods
19. Filter Drawer
20. Accessory Mounting Post Assembly
21. Red Safety Filter (C-700 Condenser Enlarger Only)

**SUPER CHROMEGA C-700 DICHOIC LAMPHOUSE**

22. Filtration Control Knobs and Scales
23. Lamphouse Access Cover
24. Light Attenuator Slot
25. Light Attenuators
26. Interchangeable Mixing Chambers
27. Interchangeable Diffusers
28. Diffuser Holders
29. White Light Lever
30. B66-XL Lifting Lever
31. B66-XL / B22 Mounting Bracket
32. B600 / C-700 / Concept Six Mounting Bracket
33. Lamphouse Retaining Nut
34. Wrench (not shown)

# Unpacking

The Omega C-700 condenser enlarger is supplied partially assembled in a single carton. The Super Chromega C-700 Dichroic Enlarger, however, is delivered in two cartons: the chassis in one box and the lamphouse in another. Unpack carefully and check all contents against the packing lists. Do not discard packing material until you have accounted for all components and mounting hardware. Since the C-700 condenser enlarger can be dismantled rather easily, it is a good idea to keep the cartons and inserts should you wish to store your enlarger in the box after use.

## IMPORTANT:

If you have purchased one of the money-saving one lens enlarger outfits, in addition to the components described in the following sections, you should have a box containing lenses and accessories. These should be checked against the carton label.

## OMEGA C-700 CONDENSER ENLARGER

After you lift off the top foam pad of the chassis carton, remove and lay aside the following components: (Hardware and small items are identified by Omega part numbers parenthetically notated.)

1. Girder/Carriage Assembly with installed lower lamphouse and condenser
2. Upper lamphouse assembly and lamp
3. Condenser module
4. Baseboard
5. Poly-bag containing filter drawer and red safety filter
6. Poly-bag containing:
  - four 1/4x20x5/8" slotted hex head girder mounting screws (9-151-3242) (A)
  - one 6/32x1 1/4" Phillips head accessory post screw (9-035-6992-58) (B)
  - one shouldered aluminum accessory post spacer (9-151-3240) (C)
  - one #6 flat washer (9-035-9312-30) (D)
  - one 1/4" curved spring washer (9-035-9318-35) (E)
7. Poly-bag containing:
  - one 1/4"-20x3/8" Phillips head screw for Lifting Lever Handle (F)
  - one 1/4" washer (G)
  - one Lifting Lever Handle (H)
  - one Line Cord Retainer (I)
  - four rubber pads (J)

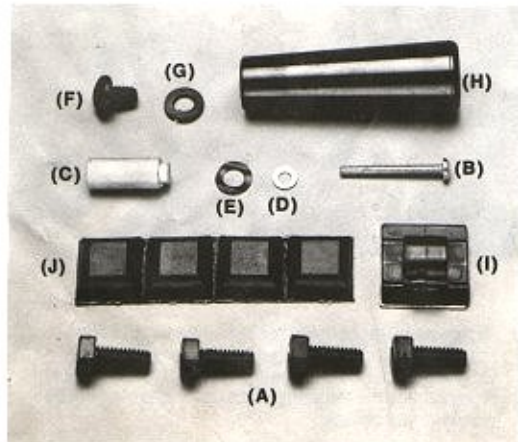

## SUPER CHROMEGA C-700 DICHOIC ENLARGER

The dichroic enlarger has modular packing, with the dichroic lamphouse in a separate carton (this is because the lamphouse is adaptable to a number of Omega enlargers.)

After you lift off the top foam pad of the chassis carton, remove and lay aside the following components: (Hardware and small items are identified by Omega part numbers parenthetically notated.)

1. Girder/Carriage Assembly with installed lamphouse adapters
2. Baseboard
3. Poly-bag containing:
  - four 1/4"-20x5/8" slotted hex head girder mounting bolts (9-151-3242) (A)
  - one 6-32x1 1/4" Phillips head accessory post screw (9-035-6992-58) (B)
  - one shouldered aluminum accessory post spacer (9-151-3240) (C)
  - one #6 flat washer (9-035-9312-30) (D)
  - one 1/4" curved spring washer (9-035-9318-35) (E)
4. Poly-bag containing:
  - one 1/4"-20x3/8" Phillips head screw for Lifting Lever Handle (F)
  - one 1/4" washer (G)
  - one Lifting Lever Handle (H)
  - one Line Cord Retainer (I)
  - four rubber pads (J)

From the lamphouse carton remove and lay aside the following:

1. Dichroic lamphouse containing 35mm mixing chamber, 35mm tapered diffuser, diffuser holder, lamp.
2. 2 1/4" x 2 3/4" mixing chamber assembly with tapered diffuser and diffuser holder.
3. Two light attenuators packed in 2 1/4" x 2 3/4" mixing chamber.
4. C-700/B600/Concept Six Mounting Bracket. (K)
5. B66-XL/B22 Mounting Bracket and B66-XL Lifting Lever (not used with Model C-700 enlarger). (L)
6. Third attenuator.



# Chassis Assembly

Review the illustrations on pages 4 and 5 (to which the identification numbers apply) and have the following tools available:

A 7/16" box, open or adjustable wrench or a broad-bladed screwdriver.

A small Phillips head screwdriver.

## MOUNTING GIRDER/CARRIAGE ASSEMBLY TO BASEBOARD — ALL MODELS

### CAUTION:

Before handling the Girder/Carriage Assembly check that the Carriage Lock Knob (9) is tight. If carriage is unlocked, the counterbalance spring (14) used to offset the weight of the Lamphouse can cause the Carriage to travel upwards with some force before the Lamphouse is mounted.

1. Carefully remove chassis, foam sections and baseboard from carton and layout all components on a clean, flat surface.
2. Open the hardware bags and lay out the contents.
3. Remove the plastic wrapper from the baseboard and turn it upside down.
4. Remove the rubber pads (J) (one at a time) from their backing. Place a pad at each of the 4 corners on the bottom of the baseboard 1" in from the corners. Press firmly.

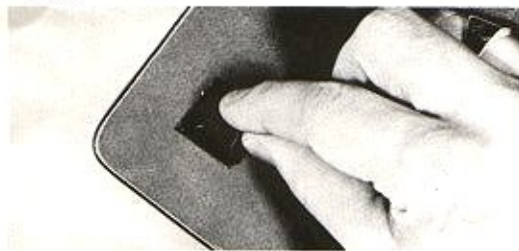

5. Position the chassis on the baseboard. Be sure the four holes in the chassis baseplate align with those of the baseboard.



6. Use the four hex bolts (A) to secure the chassis in place. Tighten using screwdriver or wrench.



7. Place the 1/4" washer (G) on the 1/4-20-3/8" Phillips screw (F) and insert the screw through the hole on the lamphouse elevation lever. Screw the handle on and tighten with Phillips head screwdriver.



8. Remove the adhesive backing from the line cord retainer (I) and attach to the right side of the carriage assembly.

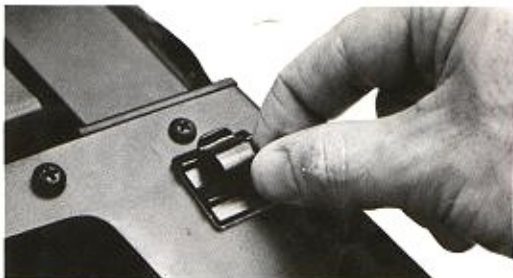

9. Remove and discard the red retaining tie wire from negative stage, bellows, lens stage assembly, and extend the bellows. (For safe shipping, the bellows is stored inside the lens stage assembly and may not be visible at first glance.)

# Lamphouse Assembly

## Condenser Lamphouse

The Omega System 700 Condenser Enlarger incorporates an advanced, double condenser optical system, in conjunction with the exclusive 75 Watt Omega "Teardrop" lamp. Condenser optical systems bring out all the fine detail in your film, producing crisp, brilliant prints. This design yields optimum light output and contrast, for use with all focal length enlarging lenses of 35-105mm. Heavy duty components are used throughout, for long dependable service life. A filter drawer is provided for using color printing and variable contrast filters.

1. Examine the glass surfaces of the condensers to make sure they are clean and dust free. If necessary, blow or wipe clean using a soft brush or lens tissue.
2. Grasp condenser module by the filter drawer guides and lower into the lower lamphouse, making sure the word *front* (stamped on the top plate) is positioned toward the front of the lamphouse.



3. Insert the filter drawer. Be sure it is fully inserted to prevent stray light leakage.
4. Check to see that the lamp is fully screwed into the upper lamphouse.
5. Position the upper lamphouse section on lower section so the left edge of the "Omega" label aligns with the mid point of the filter drawer handle. You will feel the upper lamphouse "drop" into place.



6. Twist the upper lamphouse clockwise to lock the two sections together.
7. Your Omega C-700 Enlarger accepts all standard 39mm threaded (Leica thread mount) enlarging lenses. Simply screw your lens into the lens stage.



8. Install the red safety filter as illustrated.

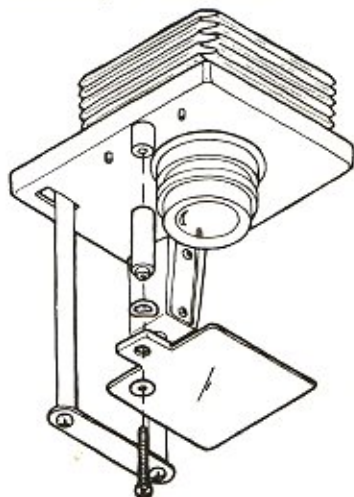

9. Be sure to insert the line cord into the line cord retainer. The cord may be connected either directly into a standard AC outlet or a timer.



Your enlarger is now completely assembled and ready to make prints.

# Dichroic Lamphouse

The Super Chromega C-700 Dichroic Enlarger features the Super Chromega C-700 dichroic lamphouse, for use with all color negatives, reversal and black and white materials. Its full diffusion design produces clean, blemish-free prints and offers unequalled evenness of illumination, and color fidelity. With 0-200cc dial-in dichroic filtration, calibrated in 1cc increments, the design also incorporates built-in infrared and ultraviolet filtration for optimum results.

**NOTE:** If you have purchased your System 700 Enlarger with a condenser lamphouse, it is unnecessary to read this page.

1. Install the adapter onto the chassis using the four slotted adapter screws, as shown.



2. With the bracket attached, move the lamphouse lifting lever forward so that it is resting on the lifting lever stop. Attach the dichroic lamphouse to the bracket using the nut, as shown.

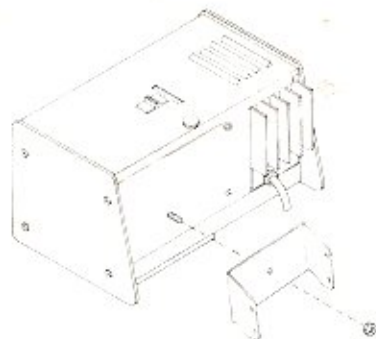

3. The lamphouse must now be aligned. Plug the lamphouse cord into a standard AC outlet or timer. Switch the unit on.

4. With a negative carrier in place, adjust the lamphouse so that the light seal at the bottom squarely contacts the top of the carrier and there are no light leaks. Check that the lamphouse appears level at the front and sides, then tighten the nut with the wrench supplied.



5. Your Omega C-700 enlarger accepts all enlarging lenses with a standard 39mm (Leica thread) mount. Simply screw the lens into the lens stage.



6. Loop the line cord connecting the lamphouse and power supply under the carriage (behind the bellows) and through the line cord retainer as illustrated.

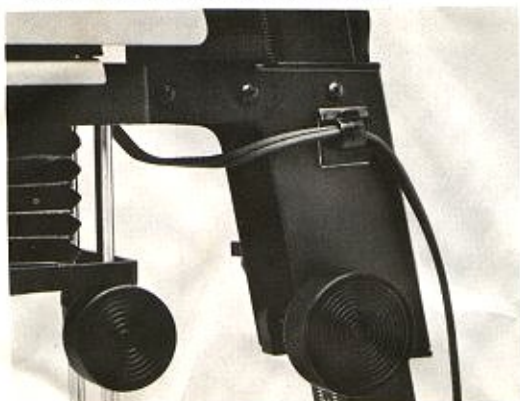

# Operating Your Omega System 700 Enlarger

1. Insert film into the negative carrier emulsion (dull) side down. The pins on the black half of the carrier act as position guides to hold film in place.



2. Pull lamphouse lifting handle forward to raise the lamphouse.



3. Insert the negative carrier between the lamphouse and the film stage, so the pins at the rear of the film stage align with the carrier cutouts. Hold the carrier in place and lower the lamphouse. **TURN OFF ALL ROOM LIGHTS.**



4. Turn the enlarger on. When using a timer, turn the timer to "FOCUS" or "ON" position.

## Electrical Connections

### CONNECTING TIMERS

Any Omega enlarging timer can be used with these enlargers. See the literature enclosed with this instruction manual. Full instructions are provided with these timers. If you are using any other timer, merely plug the line cord from the enlarger into the socket marked "Enlarger."

### CONNECTING VOLTAGE STABILIZER

With the Super Chromega C-700, we strongly recommend the use of the Voltage Stabilizer (Cat. No. 403-730). The use of a stabilizer prevents variations in printing due to line voltage fluctuations. The line cord from the enlarger is plugged into the stabilizer and the stabilizer is in turn plugged into the timer. The timer is then plugged into any 120V, 60 Hz. outlet.

### THE NEED FOR VOLTAGE STABILIZATION

"Brown Outs" or line voltage fluctuations are extremely common in many areas and are usually the result of peak demand periods such as the extensive use of air conditioners during hot summer days, etc.

If you happen to be using the enlarger while the line voltage is fluctuating, the light output and color temperature of the enlarger lamp will vary. While the effects of this may not be noticeable in black and white printing, it can cause serious problems when printing color. Pronounced color shifts, exposure errors and a lack of consistency, even when using a color analyzer, can be the result. Experienced darkroom technicians are well aware of this and most of them consider the use of a voltage stabilizer mandatory.

5. You will see a projected image on the baseboard. Place a test sheet (the size you wish to use) of exposed photographic paper (base side up) in the center of this image.



8. After obtaining proper composition and focus, place enlarging paper on easel and print.



6. Adjust elevation of the carriage to fill the desired image area on the paper. Simply turn the elevation control counterclockwise to loosen, and tighten by turning clockwise. The image may not be in focus at this point.

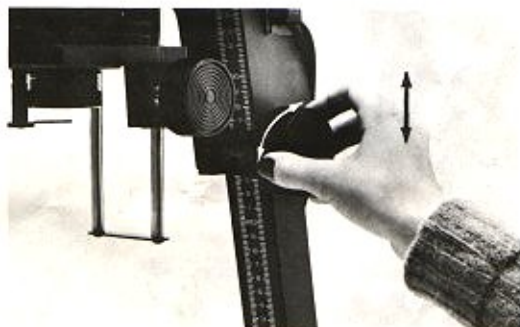

9. You may want to repeat the same image size later. It is helpful to note the lamphouse elevation as indicated on the girder's reference scale.

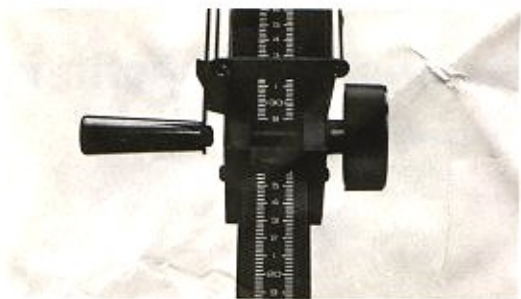

7. To focus, open the lens aperture fully and turn the focusing knob until a sharp image appears on the paper.

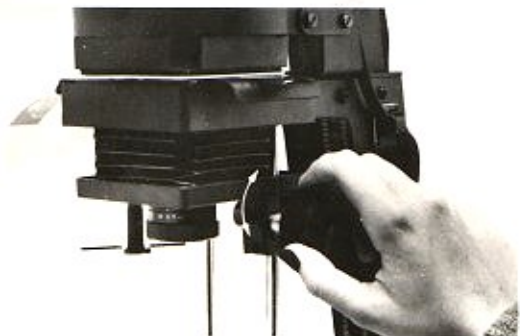

10. For enlargements exceeding 11" x 14", you may reverse the chassis for floor projection. Remove the four hex bolts at the base of the girder, turn the girder around, and replace the bolts. Counterbalance the chassis by placing a few heavy books on the baseboard.

# Enlarging Lenses

The size of the film to be printed dictates the focal length of the enlarging lens to be used. The baseboard magnification chart indicates the correct choice of lens for all film formats from 110 to 6x7cm (2 1/4" x 2 3/4").

## SYSTEM 700 MAGNIFICATION CHART

Film Format Size	Recommended Lens Focal Length	Enlargement Ratios	
		Minimum	Maximum
2 1/4" x 2 3/4"	105mm**	2.6	4.2
2 1/4" x 2 3/4"	90mm*	1.6	5.3
2 1/4" x 2 1/4"	75mm	1.06	7
35mm	40/50mm	2.9/ .55	15/11
1/2 Frame 35	35/38mm	4.1/3.4	18/16
126	40mm	3	15
110	35mm	3	15.2

### NOTE:

Any lens will enlarge film formats smaller than the recommended size, but the enlargement ratio obtainable under these circumstances will be correspondingly smaller than if a shorter focal length lens were used.

\*Condenser Reflection will make it necessary to crop your picture in order to achieve a suitable 11" x 14" print. Use 105mm lens for borderless printing.

\*\*An accessory 1" extender (Cat. No. 421-210) will permit a minimum magnification of 1.7x with the 105mm lens.

# B&W Printing Hints

## YOUR FIRST BLACK AND WHITE PRINT

Exposure time and focal length will vary with the film density, paper grade, emulsion batch, and artistic effects you are trying to obtain. To determine your starting point it is necessary to make a test strip. The following procedure is suggested.

1. Place a negative into the film carrier and into your enlarger.
2. Set the magnification for 8x10. Focus and compose.
3. Set the lens to f8.
4. Prepare an 8" x 10" piece of cardboard to use as a mask.
5. Turn-off room lights, place paper onto easel.
6. Place mask over paper exposing only about 1/6 of paper.
7. Set timer for 18 seconds and print moving the cardboard every three seconds to expose an additional 1/6 of paper.
8. From the strip choose the exposure time you consider most pleasing.

## CONTRAST CONTROL WITH THE C-700 CONDENSER LAMPHOUSE

The simplest way to control the contrast of prints is by the use of different contrast grades of paper. For more accurate contrast control, variable contrast paper is available from several manufacturers. With the use of filters of different colors, these papers will yield different degrees of contrast. For more detailed information, please see your dealer.

The ideal place to install the acetate filters used for these papers is in the filter drawer of the lamphouse. In this

location, the optical quality and cleanliness of the filters will have no effect upon the quality of the projected image. When using any filters, we recommend the incorporation of an accessory heat absorbing glass between the lamp and the filter to protect the filters. The Heat Absorbing Glass can be left in position at all times.

Alternately, variable contrast filters in plastic frames can be positioned just under the enlarging lens, in the optional swing away filter holder or by means of a holder attached directly to the enlarging lens. In this position, the filters must be kept clean and free of scratches, or the flaws and dirt will affect the quality of the finished print. Additionally, you must focus through the filter to be used, as most of these filters may cause a focus shift of the image.

Omega enlargers are ideally suited to variable contrast printing, as their high light output allows short exposure times, even when using the extremely dense high contrast filters.

## BLACK AND WHITE CONTRAST CONTROL PRINTING WITH THE SUPER CHROMEGA C-700 DICHOIC LAMPHOUSE

A black and white negative consists of minute silver particles embedded in a base of gelatin. Light passing through this material is not merely absorbed in varying degrees but will be "scattered" (somewhat like light in a dense fog). The result is that the contrast of the projected image depends on the degree of diffusion of the light with which the negative is illuminated. The contrast obtained from completely diffused light, as used in the Super Chromega C-700 dichroic is less than that obtainable with only semi-diffused system using condensers. In most instances, this is very desirable, and portrait photographers in particular have always preferred the softer graduations of diffused systems. As an approximate

measure this difference may be said to equal one-half to three-quarters of the difference between two consecutive grades of paper. Contrast, however, should not be confused with sharpness. Using the same negative and enlarging lens, the resulting print sharpness is the same irrespective of whether a condenser or diffusion type light source was employed.

We emphasize that this contrast difference exists only for black and white negatives, and not for color negatives, where the silver particles have been replaced by dyes that absorb a certain amount of light but do not scatter it. The contrast of color prints is therefore the same whether produced with a diffused or condenser light source. It is therefore recommended that users of condenser type enlargers who wish to use the Super Chromega C-700 Dichroic lamphouse for printing black and white negatives use the next higher grade paper than used previously for existing negatives. New negatives can easily be treated in the same way, of course, but it is also very easy to develop

them to a slightly higher degree of contrast by leaving them in the developer a little longer to compensate for the lower contrast of the light source.

#### VARIABLE CONTRAST PAPERS

Variable contrast papers may be used either with filters recommended by the manufacturer of such paper or with the dichroic filtration incorporated into the lamphouse. The following filtration recommendations are approximate equivalents:

Variable Contrast Filter	Equivalent Dichroic Filter Settings
No. 1	0M / 24Y
No. 1½	9M / 10Y
No. 2	25M / 4Y
No. 2½	36M / 8Y
No. 3	64M / 12Y
No. 3½	138M / 22Y
No. 4	199M / 45Y

## Color Printing Hints

### FILTRATION CONTROL WITH SUPER CHROMEGA C-700 DICHROIC LAMPHOUSE

Color printing requires filtration corrections to properly balance the print color. Your Super Chromega C-700 lamphouse provides stepless filtration from 0-200cc's for Cyan, Magenta, and Yellow. Merely dial filtration until the desired settings are indicated on the illuminated scales.

Color printing procedures and techniques depend entirely on the paper, chemicals and processing equipment you are using. Since many different color printing materials and kits are available, we refer to the specific instructions included with these products. However, to assist you in making your first prints, the following filtration, f/stop and exposure times are **SUGGESTED** as approximate starting positions for 8x10 enlargements with a standard negative (see chart at end of this section).

#### SETTING FILTRATION

The Super Chromega C-700 is equipped with three continuously variable dichroic filters that will compensate or balance any color paper characteristic for any color slide or negative. The simultaneous use of all three introduces a certain amount of neutral density, thereby extending exposure times unnecessarily. Therefore, you should adjust only two filters for any exposure with the third (usually cyan) remaining at 0.

#### NOTE:

All three color controls have a detent at the "zero" position for a positive indication when filters are completely retracted.

#### USING COLOR ANALYZER

Although for some users trial-and-error color printing may be acceptable because of modest color printing requirements, serious color printers should use a color analyzer. The use of a precision analyzer drastically cuts printing time, greatly reduces waste of paper and chemicals, and generally improves both the quality and quantity of print output.

#### EXPOSURE LIMITATIONS

Color papers have 3 emulsion layers which respond to the 3 subtractive primary colors of light.

These emulsion layers exhibit apparent sensitivities for short and long exposure times. Unfortunately, this phenomenon does not occur at precisely the same exposure times for all 3 emulsion layers and therefore color shifts are observed for very short and (to a lesser degree) very long exposure times. Thus, exposure shorter than 5 seconds and, if at all possible, longer than 40 seconds should be avoided. It is generally advisable to rely more on changes of f/ stops when adjusting exposures and change exposure times as little as possible.

#### EXPOSURE COMPENSATION

Your Super Chromega C-700 Dichroic lamphouse has the unique ability to control light output to control both f/ stop and exposure time. This is done by inserting the appropriate light attenuator in the slot on the top of the lamphouse. Each attenuator is marked with an exposure value (EV) which corresponds to a light level as follows:

EV	Percent of Transmission	Equivalent Number of f/stop Reductions
-1	50%	-1
-2	25%	-2
-3	12½%	-3

As more filtration is introduced into the light path of the lamp, more exposure time is required to maintain an equivalent print density. A change of 10cc's in cyan or magenta filter values requires approximately a 10% change in the exposure to produce equal density; a change of yellow of 10cc's is equivalent to about a 2% density change. When changing two filter colors, add (or subtract) the sum of the required changes to produce equal density values. See color correction chart at end of this section.

When both yellow and magenta filters are increased simultaneously, an approximate change of 35 points will equal 1/2 stop of the diaphragm.

#### REVERSAL TYPE PRINTS FROM TRANSPARENCIES, DUPLICATE TRANSPARENCIES, TRANSPARENCIES FROM COLOR NEGATIVES

In addition to making color prints from color negatives, the

Super Chromega Dichroic lamphouse is suitable for all other types of color printing such as:

1. Reversal type prints direct from any size transparencies (Minox to 2 1/4" x 2 3/4") using Reversal Type Papers (Type "R").

2. Duplicate transparencies direct from original, using Duplicating Films (such as Kodak Ektachrome Duplicating Film).
3. Transparencies direct from Color Negatives Films (such as Kodak Ektacolor Print Films).

#### SUGGESTED STARTING FILTRATION SETTINGS

Developing Paper	Chemistry	Film	Suggested Starting Filtration	f/stop	Exposure Time
Kodak Ektacolor 74RC	Kodak	Vericolor II	90Y 45M	f/8	12 Sec.
	EP2	Kodacolor II	75Y 55M	f/8	10 sec.
Kodak RC 1993	Kodak	Kodachrome	0Y 0M 0C	f/8	15 Sec.
	R500	Ektachrome	10M 20C	f/8	15 Sec.

#### COLOR CORRECTION CHART

Print Excess	NEGATIVES		TRANSPARENCIES	
	Recommended	Alternate	Recommended	Alternate
Red	Add Magenta & Yellow	Subtract Cyan	Subtract Magenta & Yellow	Add Cyan
Green	Subtract Magenta	Add Cyan & Yellow	Add Magenta	Subtract Cyan & Yellow
Blue	Subtract Yellow	Add Cyan & Magenta	Add Yellow	Subtract Cyan & Magenta
Cyan	Subtract Magenta & Yellow	Add Cyan	Add Magenta & Yellow	Subtract Cyan
Magenta	Add Magenta	Subtract Cyan & Yellow	Subtract Magenta	Add Cyan & Yellow
Yellow	Add Yellow	Subtract Cyan & Magenta	Subtract Yellow	Add Cyan & Magenta
Too Dark	Close Lens	Decrease Exposure Time	Open Lens	Increase Exposure Time
Too Light	Open Lens	Increase Exposure Time	Close Lens	Decrease Exposure Time

## Lamp Replacement

### SUPER CHROMEGA C-700 DICHOIC LAMPHOUSE

Catalog Number 471-400 is the 85 watt quartz halogen lamp for the Super Chromega C-700 Dichroic Lamphouse. To replace the lamp, unplug the line cord and allow the lamphouse to cool. Remove the top cover by lifting up from the rear. Remove the two knurled thumb screws which hold the top cover of the lamp housing and remove the cover. Push down on the lamp release lever with your finger. The lamp should lift free of the socket.

*Handle the new lamp by the edge of the reflector ONLY, to avoid damage to the inside of the reflector. Also, do not touch the glass lamp envelope, since moisture from*

*your fingers can etch the glass and lead to blackening and premature failure of the lamp.*

### OMEGA C-700 CONDENSER LAMPHOUSE

The Catalog Number 471-038 lamp for the Omega C-700 is a screw base lamp. To replace, simply twist off the upper lamphouse. Be sure to wipe the lamp with a lint-free cloth to remove fingerprints or moisture, as these can help to cause premature failure of the lamp. In an emergency, a standard 75W, No. 211 enlarging lamp can temporarily be used in place of the special Omega lamp. For optimum illumination, use ONLY the recommended Omega lamp.

**For 230VAC, 50 Hz. operation, the lamp replacement catalog number is 471-041.**

# Omega®

## System 700 Basic Modules

### Technical Specifications

**Maximum Film Format:** 6x7cm (2 1/4" x 2 3/4")

**Baseboard Dimensions:** 35.5x48x2.3cm (14" x 19" x 7/8")

**On Baseboard Magnification Ranges:**

Lens	Minimum	Maximum
50mm	.5	11x
75mm	1x	7x

#### Lamp:

Condenser:	75W (120V)	Cat. No. 471-038
Condenser:	75W (230V)	Cat. No. 471-041
Dichroic:	85W Quartz	Cat. No. 471-400

#### Power:

Condenser:	120VAC, 50/60 Hz. or 230VAC, 50/60 Hz.
Dichroic:	120VAC, 50/60 Hz. or 230VAC, 50/60 Hz.

#### Maximum Height:

Condenser:	99cm (39")
Dichroic:	89cm (35")

#### Shipping Weight:

Condenser:	9.1 kg. (20 lbs.)	1-carton
Dichroic:	10.2 kg. (23 1/2 lbs.)	2-cartons

## Chassis

### Key Features

The backbone of the enlarger, the chassis is designed for convenience and rigidity. All materials are heavy duty to withstand continuous use.

- Rigid steel girder with calibrated reference scale. Reversible for floor projection. Professional black finish.
- Counterbalanced carriage for smooth fingertip elevation control at all magnifications.
- High, parallel-lift action of lamphouse allows easy access to film stage for carrier insertion, film dusting and inspection.
- Precision aluminum die-cast film stage for added strength and rigidity. Built-in location pins for critical alignment and easy carrier registration.
- Die-cast aluminum lens stage, threaded to accept standard 39mm Leica thread lenses.
- Rubberized cloth bellows for flare suppression, extended range magnifications and reductions.
- Dual friction drive, stainless steel focusing rods assure smooth precise focusing action without slip or backlash. Adjustable tension control is user serviceable.
- Oversized, easy access controls for smooth, fast operation.

## Dichroic Lamphouse

### Key Features

The Super Chromega C-700 Dichroic lamphouse design provides high light output and even illumination. Its diffusion design yields superior dust and scratch suppression for minimum print retouching in both color and black and white. For use with all B600/Concept Six, B-66, B-22, C-700, and C-67 enlargers.

- Direct line operation. No external power supply required.
- A white light lever removes the dichroic filters without disturbing the setting thus increasing illumination and making focusing easier.
- Interchangeable light attenuators can control light output up to -3 EV enabling the use of optimum f/stop and exposure time.
- Continuously variable dichroic cyan, magenta, and yellow filters are fade-proof and individually calibrated for precise color control.
- Diffusion illumination system actually suppresses scratches and dust for blemish-free prints.
- Interchangeable tapered transmission diffusers and mixing chambers for even illumination center to corner, designed to compensate for light fall-off with all film formats.
- Calibrated, illuminated reference scales are magnified and color coded, scaled in 1 cc (standard color correction unit) increments, 0-200cc range for easy resetting. Zero detent for white light printing.
- Infrared absorbing filter yields purer color rendition, better color saturation.
- Ultraviolet filtration prevents off color highlights and shadows.
- Variable contrast equivalencies with PC1 — PC4 range.

- Specially designed pre-focused quartz halogen lamp operating at 85 watts, 82 volts for long life consistent color temperature, optimum light output (Cat. No. 471-400).
- Die-cast aluminum heat sink dissipates heat efficiently, keeping the film stage cool during use.
- Converts to slide duplicating light source with full color adjustment range for making internegatives, dupe slides and copying, with accessory Copy Camera Attachment (Cat. No. 429-062).
- An optional solid state Voltage Stabilizer, Cat. No. 403-730, is available.

## Condenser Lamphouse

### Key Features

The Omega Condenser lamphouse provides superior print contrast and detail, high light output and short exposure times. Double glass condensers, ground from the finest optical glass and polished to high standards guarantee the highest professional quality prints, in both color and black and white. For use with System 700/Concept Six enlargers.

- Die-cast aluminum optical chamber assures precise optical alignment.
- Clear optical glass condensers give high contrast and optimum illumination for all enlarging lenses 35-105mm.
- Special 75 watt "Teardrop" lamp with unique shape yields high light output and even illumination.
- Filter drawer accepts variable contrast, color printing and neutral density filters. Hold down tabs secure pack into position. Capacity: 12-75mm (3") square filters.
- Convection cooling prevents heat build-up, film buckling.
- Vented lampcap for safe operation temperatures and long life.
- Cold-rolled steel upper lamp cone is strong, dent-resistant and designed to stand up to heavy use.
- Three-wire cord with in-line switch and moulded, grounded plug.
- UL listed for safety.

## For further information we recommend the following reading material:

Kodak, **Basic Developing, Printing, Enlarging in Color**, AE-13

Kodak, **Basic Developing, Printing, Enlarging in Black-and-White**, AJ-2

Kodak **Color Dataguide**, R-19

Kodak **Darkroom Dataguide**, R-20

Kodak, **Creative Darkroom Techniques**, AG-18

Petersens **Guide to Creative Darkroom Techniques**

Petersens **Basic Darkroom**

# Optional Accessories for System 700 Enlargers

## Omega Copy Camera Attachment

Cat. No. 429-062

For duplicating your own slides and making color or black and white copies. Accepts "T" mount adapters for mounting almost all SLR cameras directly to the enlarger/print machine chassis. Invert the dichroic lamphouse on the base for use as a continuously variable color balance light source. Also fits all Omega B66, B22, B600 and Concept Six models.



Choice of 9 popular formats. Also fits all Omega B66, B22, B600, and Concept Six models.

Cat. No. Format

423-115	Minox
423-122	110
423-118	126
423-117	35mm Full Frame
423-123	Mounted 2"x2" Transparency
423-126	6.4cm (2-1/4"x1-5/8")
423-120	6x6cm (2 1/4"x2 1/4")
423-129	6x6cm (2 1/4"x2 1/4") with Anti-Newton Glass
423-127	6x7cm (2 1/4"x2 3/4") for C-700 only



## Omega Lens Kits

Special pre-packed one and two-lens and film carrier kits are available with a choice of the finest quality enlarging lenses. Kits consist of the appropriate focal length lens in combination with a film carrier, and include a dust cover. Available in 50mm, 75mm and 50/75mm outfits.

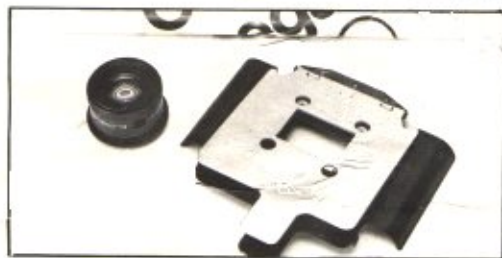

## 2. Omega Heat Absorbing Glass

Cat. No. 473-121

Supplied in metal frame, provides infrared absorption and heat suppression when using the condenser lamphouse. Recommended for use with filters, and required for best results when color printing.

## 3. Omega Portrait Diffusion Grid

Cat. No. 429-015

Wire mesh grid provides "soft" portrait effects when printing.

## 4. Omega Under-The-Lens Filter Holder

Cat. No. 429-060

Swing-away holder for use with under-the-lens accessories such as red filter, portrait grid and variable contrast filters.

## Omega Area Integrator For Color Analyzers

Cat. No. 429-158

The Omega Area Integrator is a unique optical device that permits integrated (average) readings with Omega and other color analyzers designed for spot measurement only.



## 5. Voltage Stabilizer for Super Chroma C-700 Lamphouse

Cat. No. 403-730

Solid state voltage stabilizer prevents variations in printing due to line voltage fluctuations.

## 1. Omega Film Carriers

Special spring loaded, rapid-shift design with bright top surface and non-reflective bottom. Stainless steel film guide pins assure easy film advance, location and installation.



Specifications subject to change without notice.

